

LED Lighting

Overview of LED's

LED's are Light-Emitting-Diodes. These are the lowest energy lighting options (apart from switching lights off!). They use a fraction of the energy of other forms of lighting, typically up to 90% less compared to a traditional light bulb.

This technology has developed rapidly in recent years and now can be used to replace Halogen Bulbs, strip lighting and outdoor lighting. There is a huge price range available, and usually you do get what you pay for (but not always), so check its lifetime rating, and research feedback online on certain types, uses and manufacturers.

In lighting, there are literally 1000's of diverse types, combinations and styles of light bulbs, but we will concentrate on the most common types found in British homes. Around the house there will be a range of existing lighting items, using a range of technologies (e.g. Tungsten – a standard, traditional light bulb or Halogen – often used in spotlights and outside floodlights). These are some of the least energy efficient types of light as they create significant heat.

These light bulbs will be rated in watts – usually written on the light bulb itself – 60W & 40W are typical values for a 'standard' tungsten lights, 50W, 35W or 20W are typical values for halogen spotlights. For outside floodlights that use the long, thin halogen lamps, values usually range from 300W to 500W

How to identify the lamps you need to replace

Tungsten Light bulbs:

Tungsten light bulbs will often be found in ceiling pendants, lamps with shades, wall lights and uplighters. List the power of the light bulb if you know it, if you don't, remove and see if the light bulb has a rating written on it, it will also be written on the packaging if you have a spare.

The next thing to note is the 'form' of the light bulb. For tungsten light bulbs, they would usually be either a 'standard' shape, candle or spherical.



'Standard'



Candle



Spherical
'Golf Ball' or 'Ping Ball'

Next you need to note how the light bulb is connected. There are a range of connection types from the familiar bayonet cap on a 'standard' light bulb, through to pin and screw connections.

For tungsten type light bulbs:

The three light bulbs shown in above all have the familiar bayonet cap: Bayonet Cap



Bayonet Cap

All end fittings have several ways of being referred to. For instance, the bayonet cap above on a 'standard' light bulb could also be referred to as 'BC' or 'B22' – the 22 refers to the diameter across the cap in millimetres – 22mm – easy! This convention is used across the world for referring to lamp bases and is quite straightforward.

You will find bayonet caps in 2 main varieties....



Small Bayonet Cap

B22

.....the one on the right being the B22 (or Bayonet Cap), the smaller one on the left being 'Small Bayonet Cap' (SBC) or B15 and yes, it is 15mm in diameter. You tend to find B15 caps on some candle or golf ball sized bulbs.

Other connections you are likely to come across are the 'Edison Screw' (ES) or E27 (27mm diameter) and the 'Small Edison Screw' (SES) or E14 (14mm diameter): E14 E27



E14



E27

Again, you are most likely to find the E14 on candle or golf ball light bulbs.

Halogen Spotlights:

Often found recessed into kitchen, hallway, and bathroom ceilings, they can also be found in protruding light fittings, in cabinet lighting and for highlighting features.

Again, identify the rating of the light bulb in watts (normally 50W, 35W or 20W) – this can be very difficult to read, but should you be able to read it also look out for an angle in degrees – usually somewhere between 35 and 60 degrees – this can be important and will tell you the angle of the beam of light the light bulb emits (35 degrees can be considered a narrow beam, 60 degrees plus could be considered a wide beam).

Like before, you need to identify the connection method – there are two main types:

Directly connected to the mains supply – nearly always via a 'twist and lock' pin arrangement – sometimes referred to as a 'Top Hat' connector. The official designation is 'GU10' (again the 10 indicates a distance – in this case the distance between the centre of the pins in mm):



Spotlight



Close-up of GU10 connector

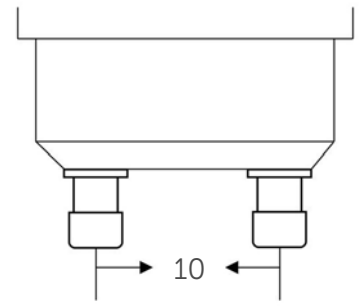

GU10 pin centres

It is worth reiterating – if a light bulb has a GU10 – it will always have mains AC delivered directly to the pins.

Connected via a transformer and fed DC voltage (often 12V). This will be identifiable by the pins being thin and straight. Nearly always referred to as 'MR16' by most people (which is incorrect as this refers to the front surface diameter in 1/8ths of an inch – so MR16 is a 2-inch front diameter – nowadays rounded to 50mm – the vagaries of the lighting terms, history and terminology is too lengthy to fully explore here, and hey, life's too short) but is a GU5.3 (yep, you guessed it, 5.3mm between pin centres):



Spotlight



Close-up of MR16 /GU5.3
connector

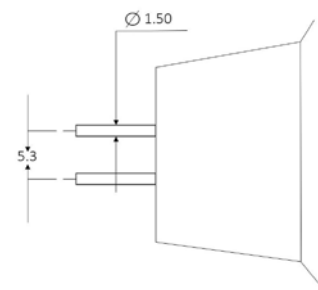

GU5.3 ('MR16') pin centres

All the spotlights above can come in switched or dimmable variations – we can only deal with lights that use on/off switches. If you are using a dimmer circuit, wish to keep the dimming function and want to go over to LEDs, seek specialist advice.

One of the great things about LED lighting is the ability to have differing types of white light. Whereas tungsten light bulbs will have a fixed colour of white light (3000K) and halogen light bulbs will have a different fixed value (4000K), LED's can be manufactured and supplied to a range of K values and hence difference versions of white light.

Techie bit – Colour temperature (or K value) of a lighting source

In simple terms the colour of white light (the 'Colour Temperature') will be rated in K (standing for Kelvin) – daylight is around 7000K and is the type of white light that the human eye copes well with (e.g. good for reading by as it gives good contrast).

The higher the K value, the bluer and less red is in the mix. So 3000K has more red and less blue and is perceived as a 'Warm White' (many manufacturers will put this on the label or packaging). Halogen light bulbs run at a higher temperature than standard tungsten and hence have a higher K value; 4000K. This is slightly less red than the 3000K, but not as crisp a white light as something nearer to daylight (say 6000K). The higher K values are often referred to as 'Cool White' (which, if you think about it, is a touch ironic).

The effect the K value of a light source will give to your room is of course subjective – but when replacing an old light bulb with an LED light bulb, keeping the K value as close as possible to the original bulb is likely to give the best results.

An example of good use of K values could be a kitchen – if predominantly wood and wood coloured surfaces, 3000-4000K tends to give a warm, pleasant effect and brings out the wood colour well. A 6000K light source in this scenario may well look out of place; too harsh and blue. Conversely, if your kitchen has predominantly white and chrome colours, a K value closer to 7000K may well give you an effect more pleasing than 3000/4000K.

To find out if you qualify for a grant contact Ridgewater Energy on:

Call: 01202 612726 | Email: info@ridgewaterenergy.co.uk

www.ridgewaterenergy.co.uk